

W A L C H E M

WAKI America Inc.

Disinfection Sensors Instruction Manual



Five Boynton Road

Hopping Brook Park

Holliston, MA 01746 USA

TEL: 508-429-1110

WEB: www.walchem.com

Notice

© 2018 WALCHEM, Iwaki America Inc. (hereinafter "Walchem")
Five Boynton Road, Holliston, MA 01746 USA
(508) 429-1110
All Rights Reserved
Printed in USA

Proprietary Material

The information and descriptions contained herein are the property of WALCHEM. Such information and descriptions may not be copied or reproduced by any means, or disseminated or distributed without the express prior written permission of WALCHEM, Five Boynton Road, Holliston, MA 01746.

Statement of Limited Warranty

WALCHEM warrants equipment of its manufacture, and bearing its identification to be free from defects in workmanship and material for a period of 24 months for electronics and 12 months for mechanical parts and electrodes from date of delivery from the factory or authorized distributor under normal use and service and otherwise when such equipment is used in accordance with instructions furnished by WALCHEM and for the purposes disclosed in writing at the time of purchase, if any. WALCHEM's liability under this warranty shall be limited to replacement or repair, F.O.B. Holliston, MA U.S.A. of any defective equipment or part which, having been returned to WALCHEM, transportation charges prepaid, has been inspected and determined by WALCHEM to be defective. Replacement elastomeric parts and glass components are expendable and are not covered by any warranty.

THIS WARRANTY IS IN LIEU OF ANY OTHER WARRANTY, EITHER EXPRESS OR IMPLIED, AS TO DESCRIPTION, QUALITY, MERCHANTABILITY, and FITNESS FOR ANY PARTICULAR PURPOSE OR USE, OR ANY OTHER MATTER.

P/N 180307.W
March 2018

Table of Contents

1.0 Introduction	1
Sensor	1
Flow Cell	1
2.0 Installation	2
Assembling the Sensor	2
Flow Cell Placement	4
Installing Sensor into Flow Cell	5
Sensor Parts Exploded View	6
Typical Installation	7
Wiring Instructions	8
3.0 Operation	13
Conditioning	13
Calibration	13
4.0 Troubleshooting.....	15
The disinfectant reading is much lower than the manual analysis	15
The disinfectant reading is much higher than the manual analysis	16
Sensor Error	16
Disinfectant Reading is Unstable	16
Calibration Failure	17
5.0 Maintenance	18
Cleaning the Membrane	18
Replacing the Membrane	18
Sensor Storage	19
6.0 Specifications.....	20
7.0 Sensor Part Numbers	24

1.0 Introduction

The Walchem disinfection sensors consist of an amperometric sensor assembly and a flow cell. Assembly of these parts is required, so please read these instructions carefully. The sensor is capable of measuring the disinfectant in clean water or in water contaminated with debris thanks to our unique flow cell design.

WDSW100, WCNP100, WDS600, W900 and WebMaster series controllers with amperometric chlorine sensors can be used for reporting chlorine residual measurements in accordance with EPA Method 334.0.

The standard (part numbers 104010, 191300, 191441, 191530 & 191587) free chlorine/bromine sensor membrane is not compatible with water containing surfactants!

Sensor

The sensor assembly includes the sensor body, a replaceable membrane cap, a 100-ml bottle of electrolyte fill solution, and special abrasive paper. Make sure that all parts are included.

The oxidizer molecules diffuse through the membrane and in the acidic environment of the electrolyte fill solution, a redox reaction occurs at the electrodes in the sensor. The current generated by this reaction is converted to a robust voltage signal that is linear with the concentration of the oxidizer.

Flow Cell

The flow cell consists of a translucent flow cell body, mounting nut and o-ring, washer set and o-ring. Make sure that all parts are included.

The flow cell is required to prevent bubble formation on the membrane and to provide proper flow velocity across the face of the membrane. The sensor will not read accurately if it is not installed in the flow cell, with a flow rate between 30 and 100 liters per hour, at an operating pressure of 1 atmosphere or less. The ¼" adapter must NOT be removed from the flow cell.

2.0 Installation

Assembling the Sensor



CAUTION: Wear gloves and safety glasses during assembly of the sensor since the electrolyte is a **STRONG ACID**. It is recommended to perform this operation over a sink with running water available. After using, re-cap any remaining electrolyte and store the bottle upside-down until the next use.

Standard Free Chlorine/Bromine Sensors (part numbers 104010, 191300, 191441, 191530 & 191587)

1. Clean just the **tip** of the working electrode with the special abrasive paper supplied. Avoid touching the electrodes! Place the special abrasive paper on top of a clean paper towel and rub the electrode tip over the abrasive paper, holding the electrode at a slight angle. Repeat several times at different angles. Never touch or clean the brown electrode shaft.
2. Remove the rubber band from the groove in the membrane cap just until the vent hole underneath is exposed, then fill the membrane cap to the top with the electrolyte fill solution. **Never shake the electrolyte bottle, it must stay free of bubbles!**
3. Hold the sensor body vertically with the tip pointing down and **SLOWLY** screw on the membrane cap until it is hand tight. **Be prepared for some electrolyte solution to squeeze out from the vent hole in the cap.**
4. Rinse your hands, the sensor, and all surfaces contaminated with electrolyte solution with running water. Check the sensor for leaks, especially at the membrane and the membrane cap threads. If any leaks are detected, tighten the membrane cap or replace it. Move the rubber band back into the groove. **Never remove the membrane cap with the rubber band covering the vent hole, or the membrane will be damaged!**
5. Push the cable onto the end of the sensor, aligning the pins with the holes. Turn the connector until hand tight to seal the cable connection.

Hydrogen Peroxide Sensors

1. The sensor is delivered with the membrane cap loosely screwed on the electrode shaft. Pull the transparent protection cap off the membrane cap and unscrew the membrane cap. Place the membrane cap onto a clean hard surface. Fill the membrane cap up to the edge with the enclosed electrolyte, empty it out and refill again up to the edge.
2. Place the G-Holder on a clean hard surface and fill it with electrolyte.
3. Lift up the G-Holder which is moisturized with electrolyte with the supplied tweezers. Insert the G-holder in the filled membrane cap. Let it down until the G-holder is held by the indentation in the middle of the membrane cap. Then remove the tweezers carefully. The G-holder stays in the membrane cap.
4. Clean just the **tip** of the working electrode with the special abrasive paper supplied. Avoid touching the electrodes! Place the special abrasive paper on top of a clean paper towel and rub the electrode tip over the abrasive paper, holding the electrode at a slight angle Repeat several times at different angles. Never touch or clean the brown electrode shaft.
5. Holding the electrode shaft upright, place it onto the filled membrane cap with the mounted G-holder. You may have to turn it counter-clockwise first until the thread catches. Then screw the electrode shaft (manually) slowly clockwise into the membrane cap. **Be prepared for some electrolyte solution to squeeze out from the vent hole in the cap.**
6. Make sure the red o-ring is in its proper position as it is the seal of the membrane cap. Screw the membrane cap (manually) tightly to the electrode shaft. The red o-ring will be firmly squeezed between the two parts. The membrane is deflected to the outside by the electrode probe.
7. Rinse your hands, the sensor, and all surfaces contaminated with electrolyte solution with running water. Check the sensor for leaks, especially at the membrane and the membrane cap threads. If any leaks are detected, tighten the membrane cap or replace it.
8. **Once the membrane cap is assembled, take care not to touch the membrane with your hand or any other object!**
9. Push the cable onto the end of the sensor, aligning the pins with the holes. Turn the connector until hand tight to seal the cable connection.

Other Sensors

1. Remove the black protective tube from the electrode tip, and clean just the **tip** of the working electrode with the special abrasive paper supplied. Avoid touching the electrodes! Place the special abrasive paper on top of a clean paper towel and rub the electrode tip over the abrasive paper, holding the electrode at a slight angle Repeat several times at different angles. Never touch or clean the brown electrode shaft.
2. Open the vial containing the membrane cap. Empty out the water. Make sure that only one grey rubber band is in the groove covering the vent hole in the membrane cap. Fill the membrane cap to the top with the electrolyte fill solution.
3. Hold the sensor body vertically with the tip pointing down and **SLOWLY** screw on the membrane cap until it is hand tight. **Be prepared for some electrolyte solution to squeeze out from the vent hole in the cap.**
4. Push the second grey band into the groove in the cap, making sure that the bands are smooth and flush.
5. Rinse your hands, the sensor, and all surfaces contaminated with electrolyte solution with running water. Check the sensor for leaks, especially at the membrane and the membrane cap threads. If any leaks are detected, tighten the membrane cap or replace it.
6. Push the cable onto the end of the sensor, aligning the pins with the holes. Turn the connector until hand tight to seal the cable connection.

Flow Cell Placement

Instructions for mounting the sensor into the process can vary greatly with the circumstances that are encountered in your application. Here are some general guidelines to assist you. Refer also to the typical installation drawings.

The sensor should be mounted such that the measuring surfaces will always stay wet. If the membrane dries out, it will respond slowly to changing disinfectant values for 24 hours, and if dried out repeatedly, will fail prematurely. **If the sensor is left dry for longer than 24 hours, the membrane cap must be replaced!**

The flow cell should be placed on the discharge side of a circulation pump or downhill from a gravity feed. Flow into the cell must come from the

bottom side that has the $\frac{3}{4}$ " x $\frac{1}{4}$ " NPT reducing bushing installed. **The reducing bushing provides the flow velocity required for accurate readings and must not be removed!**

A "U" trap should be installed so that if the flow stops, the sensor is still immersed in the water. The outlet of the flow cell must be plumbed to open atmosphere unless the system pressure is at or below 1 atmosphere. If the flow through the line cannot be stopped to allow for cleaning and calibration of the sensor, then it should be placed in a by-pass line with isolation valves to allow for sensor removal. Install the sensor vertically, with the measuring surface pointing down, at least 5 degrees above horizontal. (Refer to Installation drawings)

Flow rate regulation must be done upstream from the sensor, because any flow restriction downstream can increase the pressure above atmospheric and damage the membrane cap!

The sensor should be installed in an area where there is good solution movement and where it will respond rapidly to chemical additions. The placement of the sensor relative to the placement of chemical replenishment, along with the quality of the mixing, and the replenishment chemical flow rate are critical to accurate process control.

To avoid biological growth on the membrane, which can block measurement, never leave the sensor in water without oxidant for longer than 24 hours.

Installing Sensor into Flow Cell

1. Assemble the flow cell as shown below from the top down. The reducer should already be installed in the flow cell body.
2. Slide the 103419-B bottom washer (concave side up) over the cable end of the sensor, followed by the 103422 O-ring, followed by the 103419-T top washer (concave side down), followed by the 102586 nut.
3. Place the 102594 O-ring in the top o-ring groove of the 191279-R flow cell body.
4. Place the sensor body into the flow cell body, and tighten the 102586 nut until it is hand-tight. Before tightening completely, pull the sensor up until the clip ring is up against the bottom washer.

Sensor Parts Exploded View

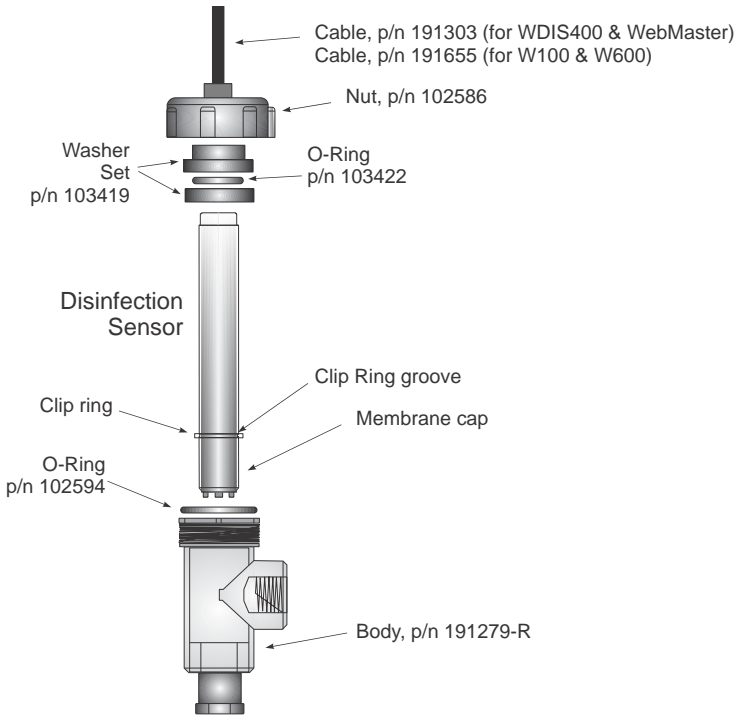

Typical Installation

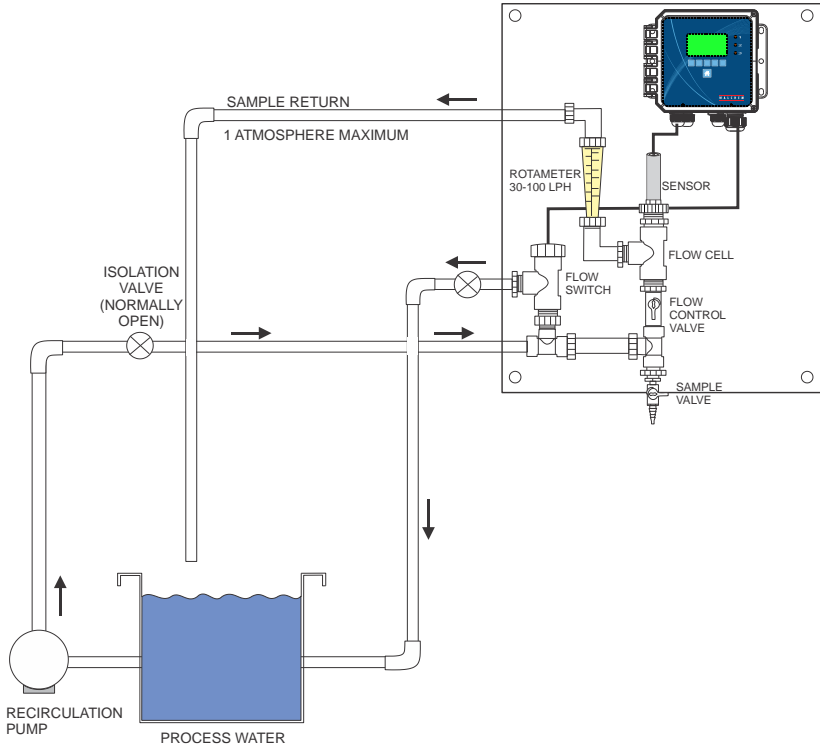

Wiring Instructions

WebMaster

The sensor is provided with a 2-twisted pair, shielded, 24 AWG, 35 pF/foot capacitance cable. The wiring to the controller is as follows:

Shield Drain:	Earth Ground
GRN:	IN+
WHT:	IN-
RED:	+5 V
BLK:	- 5 V

If the required cable length exceeds the 6 meters (20 feet) that is supplied, wire the housing to a 190851 terminal box, then use a p/n 100084 cable to reach the instrument. The maximum cable length is 30.5 meters (100 feet).

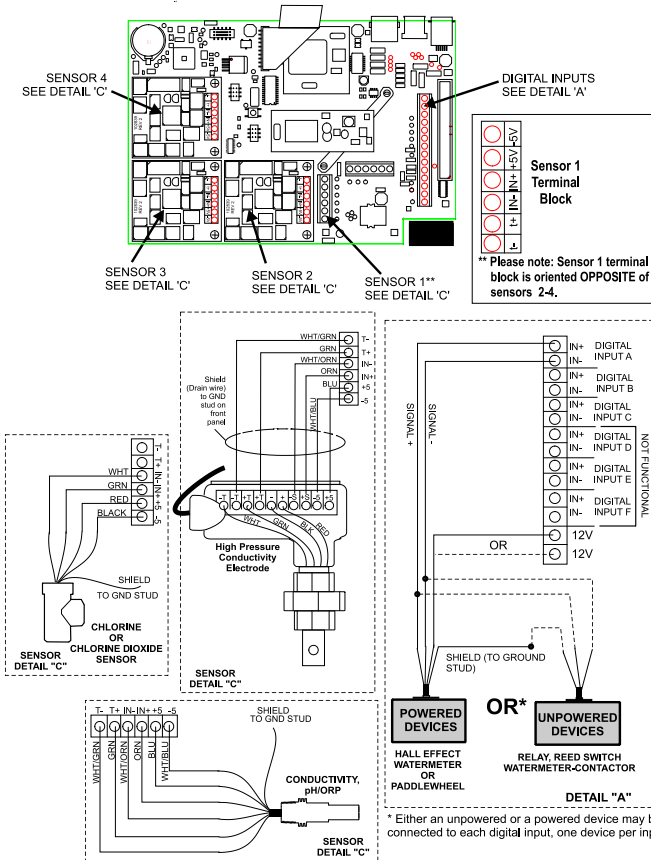

WDIS410 or WDS100 or WDS600 or W900

The sensor is provided with a 2-twisted pair, shielded, 24 AWG, 35 pF/foot capacitance cable. The wiring to the controller is as follows:

Shield Drain:	Earth Ground
GRN:	IN+
WHT:	IN-
RED:	+5 V
BLK:	- 5 V

If the required cable length exceeds the 6 meters (20 feet) that is supplied, wire the housing to a 190851 terminal box, then use a p/n 100084 cable to reach the instrument. The maximum cable length is 30.5 meters (100 feet).

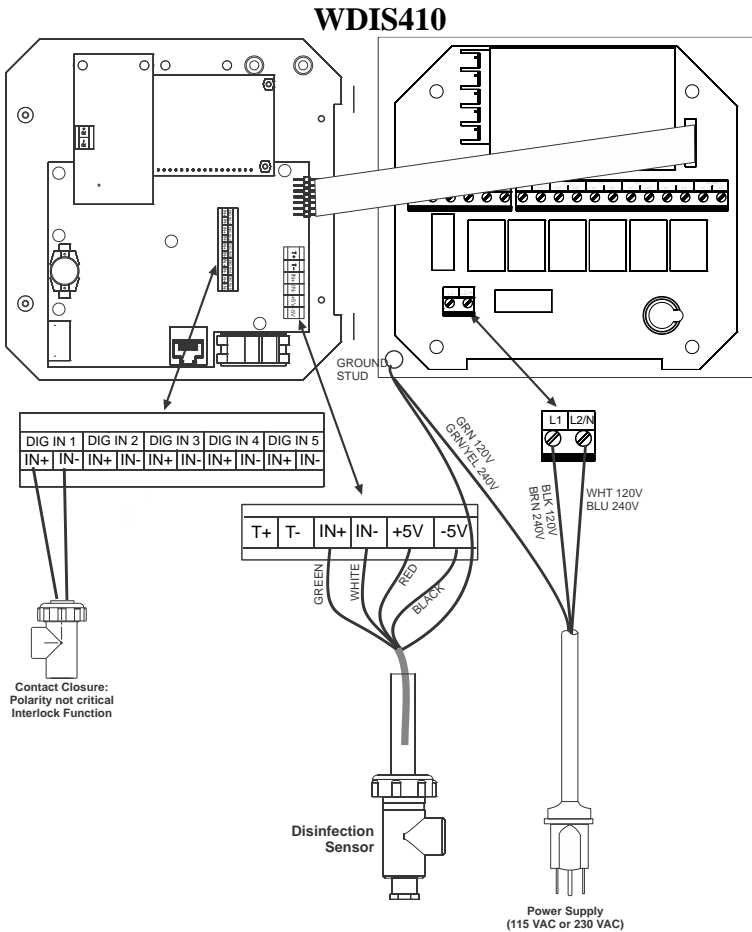

WDS600

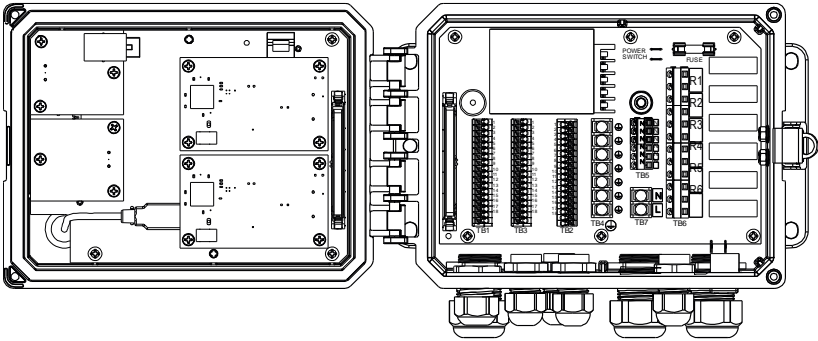

	ECOND	CCOND	pH/ORP DIS
1	TEMP-	TEMP-	TEMP-
2	TEMP+	TEMP+	TEMP+
3	R-SHLD		IN-
4		RCV	IN+
5	RCV-		
6	RCV+		
7	X-SHLD	SHIELD	SHIELD
8			+5V
9			-5V
10	XMT+	XMT	
11	XMT-		
12			

SENSOR LABEL

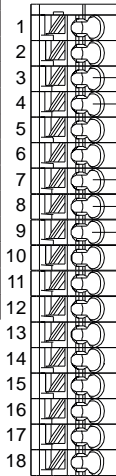

TB1 or 2

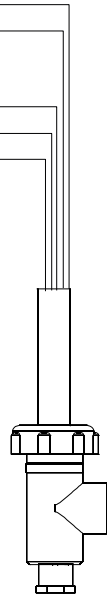

WDSW100

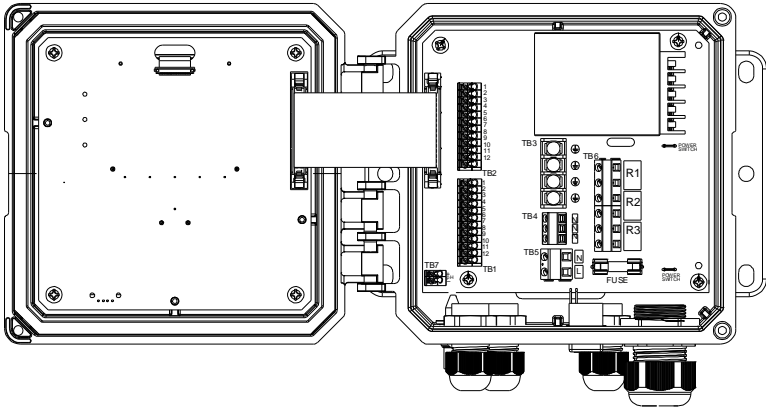

TB1	ECOND	CCOND	pH/ORP w/BNC	pH/ORP DIS	TB2	FUNCTION
1	XMT+	XMT			1	4-20 OUT-
2	XMT-				2	4-20 OUT+
3	X-SHLD	SHIELD	SHIELD	SHIELD	3	SHIELD
4				+5V	4	DIG IN 2-
5	RCV-		USE BNC FOR INPUT SIGNAL		5	DIG IN 2+
6	RCV+				6	+9VDC
7		RCV		IN+	7	SHIELD
8				-5V	8	DIG IN 1-
9	TEMP-	TEMP-	TEMP-	TEMP-	9	DIG IN 1+
10	TEMP+	TEMP+	TEMP+	TEMP+	10	+9VDC
11	R-SHLD			IN-	11	SHIELD
12					12	SHIELD

SAFETY COVER LABEL

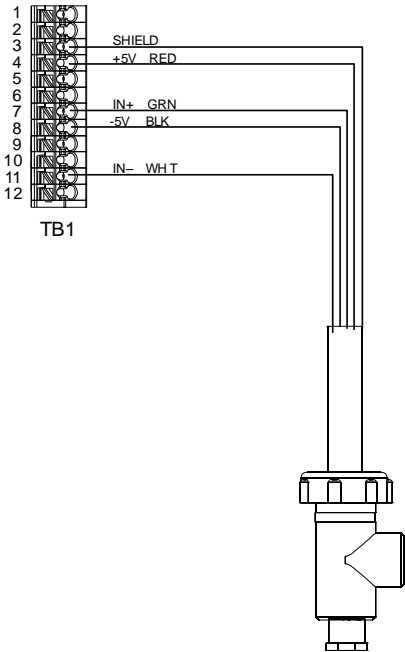

W900

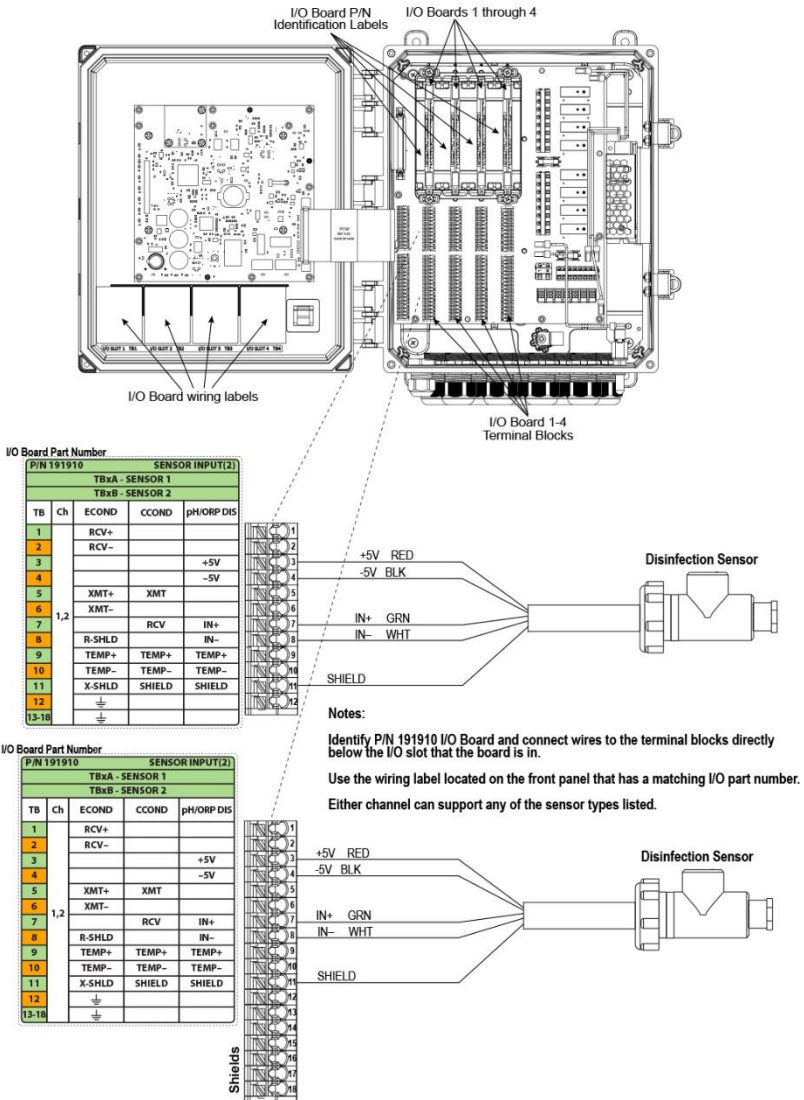

Figure 9 Part Number 191910 Dual Sensor Board Wiring - Disinfection

Zero Calibration

1. Remove the sensor from the flow cell and place it in a beaker of clean, oxidizer-free water.
2. Allow the sensor 15 minutes to equilibrate to the water temperature.
3. Go to the Zero Calibration menu of the controller. Refer to the controller instructions.
4. Stir the water with the sensor until the mV reading is stable for at least 5 minutes.
5. When the reading is stable, continue to the final steps of the calibration.
6. Return the sensor to the flow cell and check for leaks.

One Point Process Calibration

1. Ensure that the sensor is conditioned and equilibrated to the temperature of the sample.
2. Ensure that the sample flow rate is between 30 and 100 liters/hour.
3. Perform a DPD test or other manual analysis on the sample water.
4. Go to the One Point Process Calibration menu of the controller. Refer to the controller instructions.
5. When the reading is stable, continue to the final steps of the calibration.

NOTE: Disinfectant concentration can change rapidly in the sample! Minimize the time between performing the DPD test or manual analysis and finishing the calibration!

4.0 Troubleshooting

The disinfectant reading is much lower than the manual analysis

Possible Causes	Corrective Actions
Insufficient conditioning	Wait for the appropriate amount of time before attempting a calibration.
Insufficient sample flow	Increase flow rate to between 30 and 100 liter per hour.
Air bubbles on membrane	Dislodge bubbles. Adjust flow rate higher if necessary.
Dirty membrane	Clean membrane
Loose membrane cap	Tighten membrane cap.
Faulty membrane	Replace membrane cap.
High Pressure	Reduce pressure to below 1 atmosphere and refill cap with electrolyte
No electrolyte fill solution in membrane cap	Fill membrane cap with electrolyte. Replace membrane cap if it will not hold solution.
Faulty sensor	Replace sensor
Faulty analysis equipment or reagents	Consult test equipment instructions

The disinfectant reading is much higher than the manual analysis

Possible Causes	Corrective Actions
Insufficient conditioning	Wait for the appropriate amount of time before attempting a calibration.
Faulty membrane	Replace membrane cap.
Faulty sensor	Replace sensor
Faulty analysis equipment or reagents	Consult test equipment instructions
Sample contaminated with interfering molecule (refer to Sensitivity specification in Section 6)	Remove source of contamination

Sensor Error

This error message appears if the signal from the sensor is outside the range of -1400 to 1400 mVDC (WebMaster) or -2000 to 2000 (WDIS) or -2560 to 60 mV (W100/W600/900)

Possible Causes	Corrective Actions
Faulty wiring	Check wiring
Faulty sensor	Replace sensor
Faulty controller sensor input	Go to the Sensor Input menu and perform a self test. If this passes, then the problem is with the sensor or its wiring. If it fails, then disconnect the sensor from the circuit board and try the self test again. If it still fails, replace the circuit board.

Disinfectant Reading is Unstable

Possible Causes	Corrective Actions
Air bubbles on membrane	Dislodge bubbles. Adjust flow rate higher if necessary.
Air bubbles in electrolyte	Refill membrane cap with electrolyte.
Faulty membrane	Replace membrane cap.
Faulty wiring	Check wiring
Faulty controller sensor input	Go to the Sensor Input menu and perform a self test. If this passes, then the problem is with the sensor or its wiring. If it fails, then disconnect the sensor from the circuit board and try the self test again. If it still fails, replace the circuit board.

Calibration Failure

For WebMaster

The controller will display a calibration failure if the offset calculated in the Zero Calibration is outside of the range -20 to 40 mV or the slope (mV/ppm) calculated in the One Point Process Calibration is outside of the range of the nominal mV per 0.1 to 2.0 ppm.

For WDIS:

The acceptable range for the slope (mV/ppm) is the nominal mV per 0.5 to 2.0 ppm. The range of mV for a Zero Calibration is -100 mV to 100 mV.

For WI100 or W600 or 900:

The calibration will fail if the adjustment to the gain is outside of 0.2 to 10.0, or if the calculated offset is outside of -40 to 40 mV.

To calculate the nominal slope for your sensor, divide the high end of the nominal range by -2000. For example, for a 0-20 ppm sensor, the nominal slope is $-2000/20 = -100$ mV/ppm.

Possible Causes	Corrective Actions
Insufficient conditioning	Wait for the appropriate amount of time before attempting a calibration.
Insufficient sample flow	Increase flow rate to between 30 and 100 liters per hour
Air bubbles on membrane	Dislodge bubbles. Adjust flow rate higher if necessary.
Dirty membrane	Clean membrane
Faulty membrane	Replace membrane cap.
High Pressure	Reduce pressure to below 1 atmosphere and refill cap with electrolyte
No electrolyte fill solution in membrane cap	Fill membrane cap with electrolyte. Replace membrane cap if it will not hold solution.
Faulty sensor	Replace sensor
Faulty analysis equipment or reagents	Consult test equipment instructions
Sample contaminated with interfering molecule (refer to Sensitivity specification in section 6.0)	Remove source of contamination
Faulty wiring	Check wiring
Faulty controller sensor input	Go to the Sensor Input Page and perform a self test. If this passes, then the problem is with the sensor or its wiring. If it fails, then disconnect the sensor from the circuit board and try the self test again. If it still fails, replace the circuit board.

5.0 Maintenance

The sections below describe how to clean and replace the membrane cap and electrolyte solution, and also how to store the sensor when not in use.

See section 4.0 Troubleshooting for assistance in determining when maintenance may be required.

Cleaning the Membrane

Instructions for cleaning the membrane vary depending upon the type of contamination. Follow the directions for replacing the membrane shown below, replacing step 3 with one of these cleaning methods:

For general deposits:

Rinse in clear cold water.

For calcium scale:

Soak in dilute (1% by volume) hydrochloric acid, then rinse in clear cold water.

For oils:

Rinse in isopropyl alcohol.

DO NOT use cleaners or detergents containing surfactants on the standard free chlorine/bromine sensor membrane, as these will reduce the life of the membrane.

If the sensor still cannot be calibrated after cleaning, replace the membrane cap as described below.

Replacing the Membrane



CAUTION: Wear gloves and safety glasses during assembly of the sensor since the electrolyte is a **STRONG ACID**. It is recommended to perform this operation over a sink with running water available. After using, re-cap any remaining electrolyte until the next use.

1. **Always move the gray band(s) to uncover the vent hole before removing the membrane cap, or else the membrane will be destroyed!** Hold the sensor vertically with the membrane facing down and carefully unscrew the membrane cap.
2. Rinse the electrolyte fill solution off the cap and electrodes with cold water.
3. Discard the old membrane cap.
4. Unpack the new membrane cap, taking care not to touch the membrane or get it dirty.

5. Fill the membrane cap to the top with the electrolyte fill solution.
6. Hold the sensor body vertically with the tip pointing down and SLOWLY screw on the membrane cap until it is hand tight. **Be prepared for some electrolyte solution to squeeze out from the cap.**
7. Rinse your hands, the sensor, and all surfaces contaminated with electrolyte solution with running water.
8. Check the sensor for leaks, especially at the membrane and the membrane cap threads. If any leaks are detected, tighten the membrane cap or replace it. Move the rubber band(s) back into the groove.

Sensor Storage

The sensor may be stored for up to one month in the flow cell assuming that the membrane is always kept submerged in water.



For long term storage, up to 3 years, follow this procedure:

CAUTION: Wear gloves and safety glasses during assembly of the sensor since the electrolyte is a **STRONG ACID**. It is recommended to perform this operation over a sink with running water available. After using, re-cap any remaining electrolyte until the next use.

1. Hold the sensor vertically with the membrane facing down and carefully unscrew the membrane cap. Always move the gray bands to uncover the vent hole before removing the cap!
2. Rinse the electrolyte fill solution off the cap and electrodes with cold water.
3. Allow the parts to air dry.
4. Loosely screw the membrane cap back on and store the sensor in a clean dry place. The electrode tip must not touch the membrane.
5. The old membrane cap used to protect the sensor during storage must be discarded and replaced when the sensor is put back into service.

6.0 Specifications

Calibration	Weekly
Change electrolyte	3-6 months
Change membrane cap	1 year
Electrical	
Power requirements	±5 VDC, 5 mA maximum
Signal	0 to -2000 mVDC
Maximum cable length	100 feet (30.5 meters)
Extension cable	2 twisted pair, 22 AWG, shielded, 35 pF/ft (Walchem 100084 or Belden 8723)
Mechanical	
Operating Temperature	Free Chlorine/Bromine Free Chlorine/Bromine (Extended pH Range) 0 to 45°C (32 to 113°F) Total Chlorine
	<hr/> Chlorine Dioxide 0 to 50°C (32 to 122 °F)
	<hr/> Peracetic Acid 0 to 45°C (32 to 113 °F)
	<hr/> Ozone 0 to 50°C (32 to 122 °F)
	<hr/> Hydrogen Peroxide 0 to 45°C (32 to 113 °F)
Operating Pressure (Sensor)	0 to 3 atmosphere (0 to 44 psi) – Total Chlorine (CP4) 0 to 1 atmosphere (0 to 14.7 psi) – All other sensors
Operating Pressure (Optional flow switch)	0 to 10.3 atmosphere (0-150 PSI) <i>see graph on next page</i>
Storage	Sensor: Frost-protected, dry and without electrolyte no limit at >5 to <40°C (>41 to <104 °F) Membrane cap: Used membrane caps cannot be stored! Electrolyte: in original bottle protected from sunlight min. 1 year at >5 to <25°C (>41 to <77°F)
Flow cell inlet	¼" NPTF
Flow cell outlet	¾" NPTF
Wetted materials of construction	
Sensor	Free Chlorine/Bromine PVC, Polycarbonate, Silicone rubber
	<hr/> Free Chlorine/Bromine (Extended pH Range) Total Chlorine PVC, Polycarbonate, Chlorine Dioxide Silicone rubber, SS, PEEK Peracetic Acid Ozone Hydrogen Peroxide
Flow cell body	Isoplast
O-Ring	FKM

Operating Pressure (Optional flow switch)

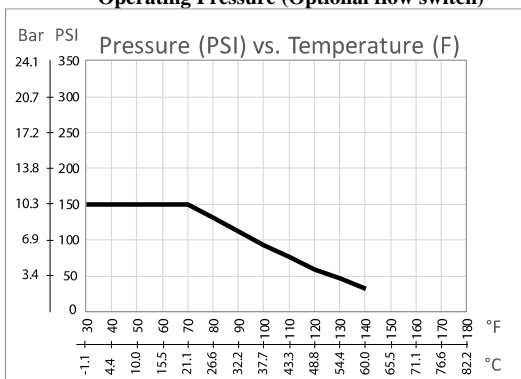

Free Chlorine/Bromine

Range (W100, W600, W900)	Range (WDIS)	Range (WM1, WIND)	Resolution
0-2 mg/l	0-1.33 mg/l	0-0.8 mg/l	0.001 mg/l
0-20 mg/l	0-13.25 mg/l	0-8 mg/l	0.01 mg/l
0-200 mg/l	0-132.5 mg/l	0-80 mg/l	0.1 mg/l

Sensitivity	HOCl (100%) HOBr (100%) Ozone ClO ₂ (900%) Not for use with isocyanuric acid or stabilized bromine
Sample Flow rate	30 to 100 liters/hour (0.13 to 0.44 gal/min)
pH Range	6.8 – 8.0 (pH must be stable within ± 0.10)
Conductivity Range	Up to 4% NaCl
Response time	30 sec
Conditioning time	60 min

Free Chlorine/Bromine- Extended pH Range

Range (W100, W600, W900)	Range (WDIS)	Range (WM1, WIND)	Resolution
0-20 mg/l	0-12.5 mg/l	0-7.5 mg/l	0.01 mg/l

Sensitivity	HOCl (100%) HOBr (100%) Ozone ClO ₂ (100%) HOCl with isocyanuric acid Not for use with stabilized bromine
Sample Flow rate	30 to 100 liters/hour (0.13 to 0.44 gal/min)
pH Range	4.0 – 12.0
Conductivity Range	No Limit
Response time	2 min
Conditioning time	120 min

Total Chlorine

Range (W100, W600, W900)	Range (WDIS)	Range (WMI, WIND)	Resolution
0-20 mg/l	0-16.75 mg/l	0-10 mg/l	0.01 mg/l
Sensitivity	ClO ₂ (100%) Ozone (130%)		
Sample Flow rate	30 to 100 liters/hour (0.13 to 0.44 gal/min)		
pH Range	4.0 – 12.0		
Conductivity Range	No Limit		
Response time	2 min		
Conditioning time	120 min		

Chlorine Dioxide

Range (W100, W600, W900)	Range (WDIS)	Range (WMI, WIND)	Resolution
0-2 mg/l	0-1.67 mg/l	0-1.0 mg/l	0.001 mg/l
0-20 mg/l	0-16.75 mg/l	0-10 mg/l	0.01 mg/l
0-200 mg/l	0-167.5 mg/l	0-100 mg/l	0.1 mg/l
Sensitivity	Free Chlorine (5%) Ozone (2500%)		
Sample Flow rate	30 to 100 liters/hour (0.13 to 0.44 gal/min)		
pH Range	1.0 – 11.0		
Conductivity Range	No Limit		
Response time	30 sec		
Conditioning time	60 min		

Peracetic Acid

Range (W100, W600, W900)	Range (WDIS)	Range (WMI, WIND)	Resolution
0-200 mg/l	0-167.5 mg/l	0-100 mg/l	0.1 mg/l
0-2,000 mg/l	0-1,675 mg/l	0-1000 mg/l	1 mg/l
0-20,000 mg/l	0-16,750 mg/l	0-10,000 mg/l	10 mg/l
Sensitivity	Ozone (250%) ClO ₂ (100%) H ₂ O ₂ (0.5%)		
Sample Flow rate	30 to 100 liters/hour (0.13 to 0.44 gal/min)		
pH Range	1.0 – 7.0		
Conductivity Range	No Limit		
Response time	3 min		
Conditioning time	60 min		

Ozone

Range (W100, W600, W900)	Range (WDIS)	Range (WMI, WIND)	Resolution
0-20 mg/l	0-16.75 mg/l	0-10 mg/l	0.01 mg/l

Sensitivity ClO₂ (6%)

Sample Flow rate 30 to 100 liters/hour (0.13 to 0.44 gal/min)

pH Range 2.0 – 11.0

Conductivity Range No Limit

Response time 50 sec

Conditioning time 60 min

Hydrogen Peroxide

Range (W100, W600, W900)	Range (WDIS)	Range (WMI, WIND)	Resolution
0-200 mg/l	0-167.5 mg/l	0-100 mg/l	0.1 mg/l
0-2,000 mg/l	0-1,675 mg/l	0-1000 mg/l	1 mg/l
0-20,000 mg/l	0-16,750 mg/l	0-10,000 mg/l	10 mg/l

Sensitivity Chlorine (none may be present)
PAA (none may be present)
Ozone (none may be present)

Sample Flow rate 30 to 100 liters/hour (0.13 to 0.44 gal/min)

pH Range 2.0-11.0

Conductivity Range No Limit

Response time 5-10 min

Conditioning time 180 min

7.0 Sensor Part Numbers

Walchem Part Numbers			
	Sensor	Membrane	Electrolyte
SENSOR, Cl ₂ /Br ₂ , 0 PPM	104010	104103	104104
SENSOR, Cl ₂ /Br ₂ , 2 PPM	191530	103463	103474
SENSOR, Cl ₂ /Br ₂ , 20 PPM	191300	103463	103474
SENSOR, Cl ₂ /Br ₂ , 200 PPM	191441	103463	103474
SENSOR, Cl ₂ /Br ₂ , 200 PPM, 4-20 mA	191587	103463	103474
SENSOR, Cl ₂ /Br ₂ , 20 PPM, EXT PH	191445	103712	103726
SENSOR, TOTAL Cl ₂ , 20 PPM (CP2.1)	191492	103712	103713
SENSOR, TOTAL Cl ₂ , 20 PPM (CP4)	104165	104166	103713
SENSOR, ClO ₂ , 2 PPM	191532	103462	103475
SENSOR, ClO ₂ , 20 PPM	191280	103462	103475
SENSOR, ClO ₂ , 200 PPM	191534	103759	103475
SENSOR, ClO ₂ , 2 PPM, 4-20 mA	191648	103462	103475
SENSOR, ClO ₂ , 5 PPM, 4-20 mA	191650	103462	103475
SENSOR, H ₂ O ₂ , 200 PPM (WP7)	191537	103462	103761
SENSOR, H ₂ O ₂ , 2000 PPM (WP7)	191539	103462	103761
SENSOR, H ₂ O ₂ , 20000 PPM (WP7)	191541	103759	103761
SENSOR, H ₂ O ₂ , 200 PPM (WP10)	103985	103991	103761
SENSOR, H ₂ O ₂ , 2000 PPM (WP10)	103987	103991	103761
SENSOR, H ₂ O ₂ , 20000 PPM (WP10)	103989	103992	103761
SENSOR, OZONE, 2 PPM	191746	103979	103500
SENSOR, OZONE, 20 PPM	191320	103498	103500
SENSOR, PAA, PVC, 200 PPM	191490	103462	103501
SENSOR, PAA, PVC, 2000 PPM	191338	103462	103501
SENSOR, PAA, PVC, 20000 PPM	191512	103759	103760
SENSOR, PAA, PEEK, 2000 PPM	103781	103758	103501
SENSOR, PAA, PEEK, 20000 PPM	103741	103758	103501

5 BOYNTON ROAD
TEL: 508-429-1110

HOPPING BROOK PARK

HOLLISTON, MA 01746 USA

Web: www.walchem.com

