

IWAKI PUMPS

Iwaki Multifunction Valve
The MFV
Instruction manual

Read through this instruction manual before use!

T723

■Safety instructions

Depressurize a plumbing system!

Be sure to release pressure from plumbing before work.

Turn off power!

Be sure to turn off power to stop the pump and related devices before work. Otherwise, liquid may gush out.

Wear protective clothing!

Getting wet with chemicals may result in a chemical burn. Always wear chemical clothing such as a protective mask and gloves in order to reduce the risk.

Do not remodel the pump!

Remodelling this product carries a high degree of risk.

Specified application only!

Do not use this product to any application other than specified one. Otherwise, personal injury or property damage may result.

Restriction on installation!

This product is not watertight. Do not place this product in a humid place or wet it with liquid. Otherwise, Failure may result.

Use specified tube only!

Unauthorized tubes may pop off and cause chemical leak.

Damaged product!

Risk of electrical shock or leak. Do not use a damaged product.

Observe these safety instructions. Otherwise, personal injury or property damage may result!

IWAKI CO.,Ltd.

6-6 Kanda-Sudacho 2-chome, Chiyoda-ku Tokyo 101-8558
Japan

Tel: (81)3 3254 2935 Fax: (81)3 3252 8892

■Product outline

This product is developed for use with Iwaki electromagnetic metering pumps and functions as air vent valve, back pressure valve, relief valve and a way of releasing discharge line pressure. The pump head can be easily retrofitted with the multifunction valve after a pre-installed air vent valve.

■Specification

1. Identification code

MFV - H TC - 1
a b c d

a : Model

b : Set pressure

Code	Back pressure valve (MPa)	Relief valve (Mpa)
H	0.25±0.1	1.25±0.2
M	0.25±0.1	0.55±0.1
L	0.1±0.05	-

c : Wet ends

Code	Body	O ring	Diaphragm
TC	PVDF	FEPM	PTFE+EPDM (Not a wet end)

Material code PVDF: Polyvinylidene fluoride
FEPM: Tetrafluoroethylene/propylene rubber
PTFE: Polytetrafluoroethylene
EPDM: Ethylene propylene diene monomer

d : Tube connection bore

Code	Tube bore
2	ø4×ø6
3	ø6×ø8
5	ø9×ø12
6	ø10×ø12
7	ø1/4×ø3/8
8	ø3/8×ø1/2
23	ø6×ø12
24	ø5×ø8

2. Liquid temperature : 0-60°C

3. Ambient temperature : 0-40°C

■Applicable pumps

This product is applicable to the following pumps.

Model	Pump size
MFV-HTC-2/3/7/23/24	B11/B16/C16/C21
MFV-MTC-2/3/7/23/24	B21
MFV-MTC-5/6/8	C31
MFV-LTC-5/6/8	B31/C36

■Installation

Turn off power and check the pump has stopped before work!
Release the discharge line pressure before work!

1. Turn the Lock nut anticlockwise and take out a pre-installed air vent valve from the pump head.
2. Mount the multifunction valve to the pump head and fasten the Lock nut clockwise.
3. Connect a discharge line and air vent line to corresponding port on the valve. See the instruction manual of the pump for detail.
4. Run the pump and check for a leak.

■Operation

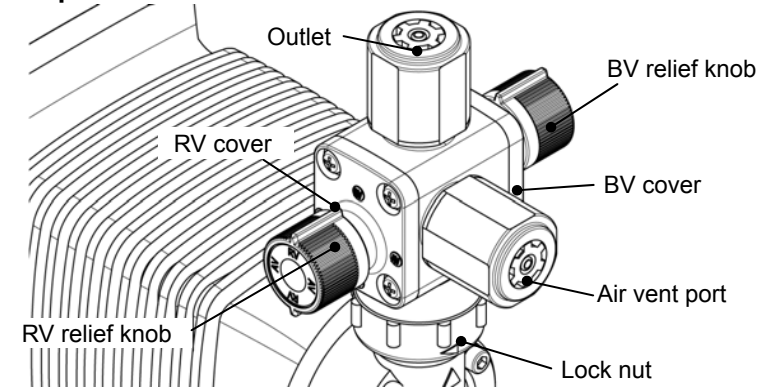

Rotate BV and RV relief knobs and activate a desired function. Each knob clicks every 90-degree rotation, indicating two different functions in turn.

○BV (Backpressure Valve) :
Back pressure valve is active. Select this function for normal operation.

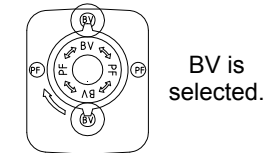

○PF (Pressure Free) :
Discharge line pressure is being released. Note "AV" must be selected on the other side at this time.

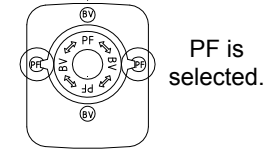

○RV (Relief Valve) :
Relief valve is active. Select this function for normal operation.

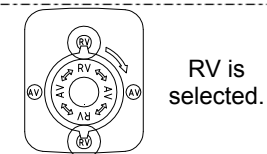

○AV (Air Vent) :
Air vent valve is active.

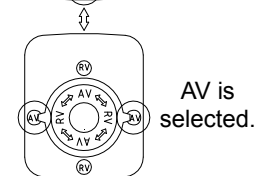

1. Degassing

- a. Rotate the RV relief knob and select "AV".
- b. Run the pump until air has been expelled and liquid starts to come up through the air vent port.
- c. Return the relief knob to "RV".

2. Back pressure valve and Relief valve

- a. After air has been expelled, select "BV" and "RV" and then start operation. A relief valve becomes ready to function and a certain level of back pressure is maintained during operation.
- b. Once discharge pressure has reached the set pressure of the relief valve, the valve starts to expel liquid through air vent port.

When back pressure is not kept or the relief valve does not function, either relief knob may be out of a proper position. Always rotate the knob until it clicks!

3. Discharge line pressure release

- a. Stop the pump.
- b. Select "PF" by the BV relief knob to disable the back pressure valve.
- c. Rotate the RV relief knob to "AV" to release discharge line pressure through the air vent port.

Be sure to check liquid belches out through the air vent port. If not, discharge line pressure may have not been released!

■Maintenance & Inspection

Check the following points and stop operation upon sensing abnormalities. See "Troubleshooting" below in order to resolve problems.

Item	States	Points to be checked	How to check
1	Flow rate failure	A position of RV relief knob	Flow meter/ Visual check
2	Leak problem	Check for a leak and tighten joints.	Visual check
3	Air ingress from loose joints	Check a line and tighten joints.	

■Troubleshooting

States	Possible causes	Solutions
Unsteady flow rate	BV relief knob hasn't come to a proper position, so that overfeeding is caused.	Rotate the knob until it clicks at a proper position.
	RV relief knob hasn't come to a proper position, so that a leak is caused from the air vent port.	Rotate the knob until it clicks at a proper position.
Leakage	Lock nut is loose.	Fasten the Lock nut.
	O ring is out of place.	Fit the O ring in place.

■Warranty

Scope

1. Warranty period: One year after delivery
2. Repair without charge: Any failed or damaged product resulted within the warranty period from a design or manufacturing error will be repaired without charge.
3. Repair with charge: Any repair of a failed or damaged product which falls under the following cases will be charged.
 - a. The product is out of warranty period.
 - b. Failure or damage is due to incorrect handling.
 - c. Failure or damage due to the use of unauthorized parts.
 - d. Failure or damage due to unauthorized repair or modification.
 - e. Failure or damage due to act of providence such as earthquake or fire.
4. We are not responsible for any failure or damage on a product that is developed based on the specifications or materials specified by you.
5. The materials we selected for the product are recommendable ones. We are not responsible for any chemical corrosion or wear.
6. We are not responsible for any property damage and related expense due to product failure.

■Repair

Stop operation upon sensing abnormal condition and check/solve problems. An early check and corrective action will help prevent a failure or accident.

1. Read this instruction manual thoroughly before repairs.
2. Contact us or your host machine maker (when built-in application) for repair.
3. Flush the inside of the pump to remove residual chemicals before return.
4. Contact us for repair with the following information.
 - a. Model code and Mfg. number: See nameplate.
 - b. Operating period and condition (Liquid, concentration, temperature, slurry, piping layout, etc.)
 - c. Failure detail and state.